

Safety Group with non return 0034

safety group to protect unvented water heaters



Field of application

The small and compact Safety Group type 34 is used to protect unvented electrically heated usually wall-mounted potable water heaters with a maximum volume of up to 200 L. It is a reliable and well-designed compact valve in the form of an in-line model. The protection is ensured by a safety valve and a check valve.

The safety valve protects the downstream potable water heater by automatic opening, which prevents the pressure from exceeding the admissible operating pressure. The check valve prevents the backflow of heated potable water into the supply line.

Design

The operational parts in the pressure relief valves are protected against direct contact with the fluid (protection against corrosion). The pressure relief valves can be lifted by

means of a rotatable handle. Cleaning the seat and the seal after having removed the head part will not have changed the opening pressure.

Safety Group with non return 0034

Materials

The body is chrome-plated and made of a high-quality low-lead brass alloy; the spring cap, the diaphragm and other internal parts

are made of heat and ageing resistant elastomeric synthetic material and the spring of corrosion resistant spring steel wire.

Installation

We recommend to install the safety group 0034 vertically with the inlet connections facing downwards. The length of the supply pipe shall not exceed 1 m, bends are not admissible and its nominal size must be the size of the valve inlet. Position the valve at the highest point of the heat-generating device or in the safety pipe close to the heat-generating device. There shall be no isolating valves, strainers or similar devices in the supply pipe. The diameter of the relief pipe must be at least equal to the nominal size of the valve outlet. The relief pipe has to be installed with continuous incline. It can maximally include 2 bends and have a length of 2 meters. When a length exceeding 2 m is necessary, the pipe

must be one size larger. Caution: more than 3 bends and a length exceeding 4 meters are not admissible. The outlet of the relief pipe must be free from obstruction, controllable and positioned in such a way that persons are not endangered by steam relief. When the relief pipe ends over a tundish, it is indispensable that its drain pipe has at least the double cross section of the valve inlet. Free access to the pressure relief valve must be provided. Thoroughly flush the pipe prior to installation. Install the pressure relief valve under consideration of the flow direction (see arrow on the body) in compliance with the instructions.

Technical data

Connection size:	DN 15 and DN 20
Opening pressure:	6, 8 and 10 bar
Fluids:	water, other neutral non-adhesive fluids
Operating temperature:	max. 90 °C
Serial number:	0034 ...

Maintenance

The correct function of the pressure relief valve should be checked by qualified personnel at initial operation and then once a year: turn the lifting handle in the direction of the arrow until you hear a click. Afterwards, the valve has to be closed tight. Should the valve drip constantly, it is very likely that impurities have built up in the seat. Depressurise the system to carry out service works: isolate the cold

water supply and drain the hot water pipes. Then, maintenance works on the valve can be carried out. To clean the valve seat and seal, unscrew the head part. After cleaning, refit the head part; the opening pressure remains unchanged after this operation. In case of repair or service, you can order a separate exchange cartridge under article no. 2116.20....

Safety Group with non return 0034

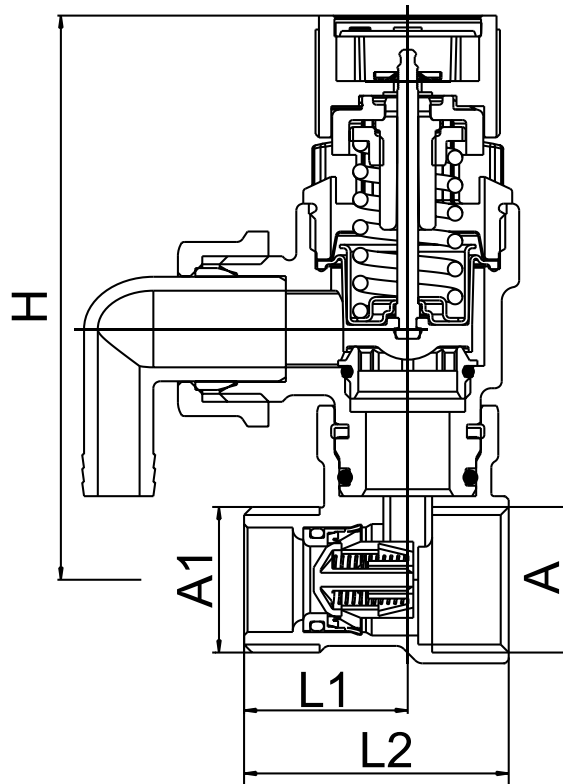

Nominal size		DN 15	DN 20
	A	G 1/2"	G 3/4"
	A1	G 1/2"	G 3/4"
Dimensions in mm	H (mm)	81	81
	L1 (mm)	23,5	23,5
	L2 (mm)	38	38

Inlet -> male threads ; Outlet -> female threads

Safety Group with non return 0034

Components / Order numbers

①
Valve body

②
Service cartridge
2116.20.006

